

PLAN ELEVATION

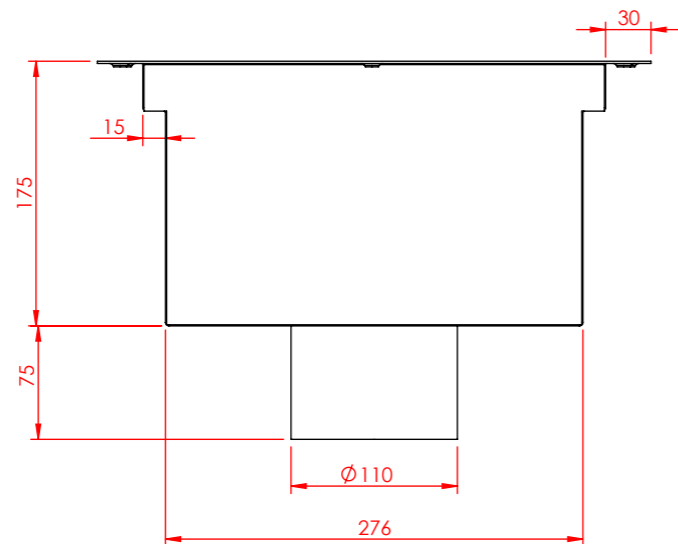

FRONT ELEVATION

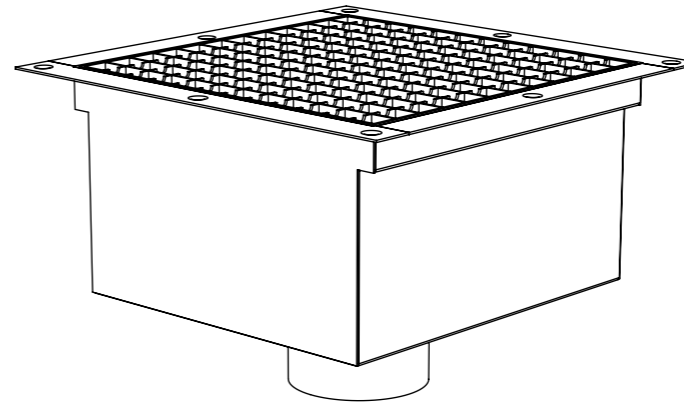
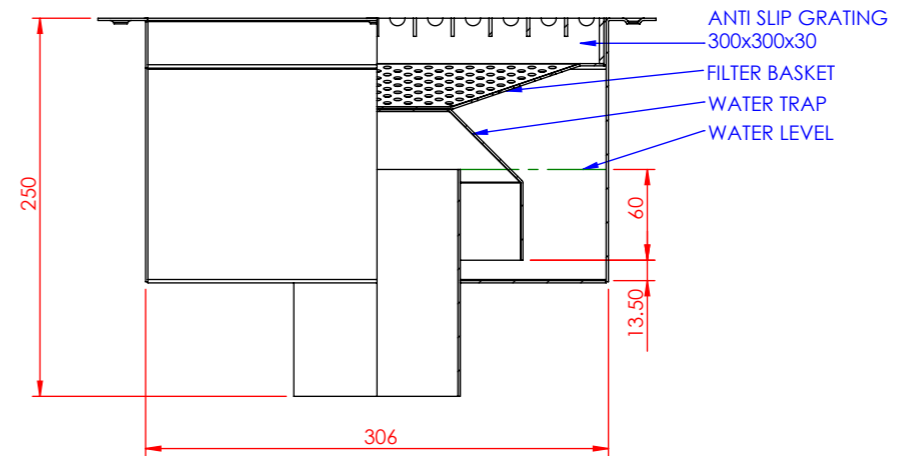

SIDE ELEVATION



59-62 BRINDLEY ROAD
ASTMOOR INDUSTRIAL ESTATE
RUNCORN, CHESHIRE WA7 1PF
TEL: 01928 563532
FAX: 01928 580224

THIS DRAWING REMAINS THE PROPERTY OF ALULINE GROUP AND MAY NOT BE COPIED, REPRODUCED, LENT OR DISCLOSED WITHOUT THEIR EXPRESS PERMISSION.

ALULINE GROUP RESERVE THE RIGHT TO MAKE A CHARGE FOR DRAWING/S

PROJECTION

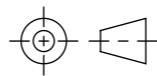

DIMENSIONS IN MILLIMETERS (mm)

DRAWN BY: ctorralba

DATE: 06.04.2010

TITLE:

300x300x200 gully

DRAWING NO.

GU-1012

SCALE:

1:5 @ A3

REV

?